

PROPRIETARY ASSEMBLY

LABEL NOTES:

1. Label tubing 2 inches behind connector boot:

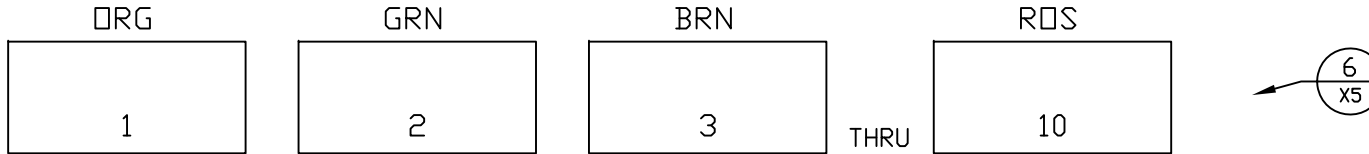

2. Label (CCL003) assembly 6 inches from breakout as shown:

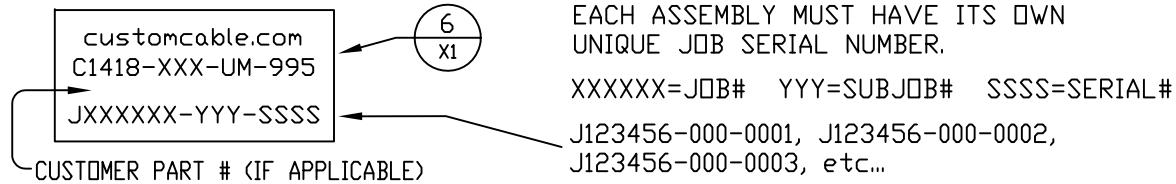

3. Print kit bin and wirecut labels (CCL007):

Kit bin (1 per job):

Wirecut (1 per cable):

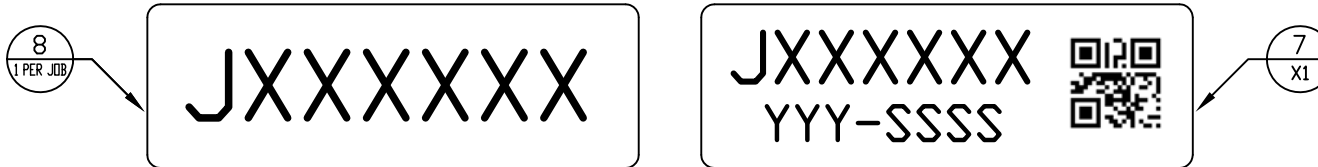

4. Label (CCL007) assembly bag/spool as shown:

XXX = Length in Feet, Inches, Meters, etc.
 UM = unit of measure: IN, MT etc.,
 leave out if Feet

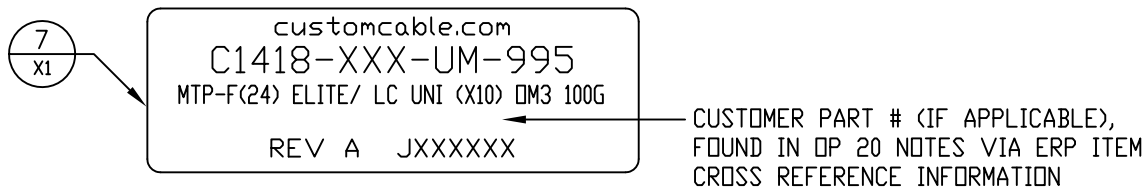























WIRE CUT INSTRUCTION

FURCATION TUBING TO BE CUT AS FOLLOWS

10 PIECES @ 24 INCHES LONG

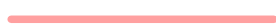
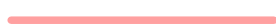
 <p>AN MFLIGHTWAVE COMPANY</p>	UNLESS SPECIFIED	APPROVALS			MM	DD	YY	Title: MTP-F(24) ELITE/ LC UNI (X10) OM3 100G
	TOLERANCE: 0-18 inches +/- 1/2" Over 18 inches +3% / -2%	Drawn B. Baylor	03	06	15	Part No. C1418-XXX-UM-995	Rev. A	
ASSEMBLY: CENTER LABEL IF LENGTH IS LESS THAN 12 INCHES	Checked	03	06	15	Dwg No. C1418			Sheet 1 of 3
THIS DRAWING MAY CONTAIN PATENTED OR PROPRIETARY INFORMATION AND MUST NOT BE USED FOR ANY PURPOSE DETRIMENTAL TO CUSTOM CABLE INDUSTRIES, INC. IT MAY NOT BE REPRODUCED OR TRANSCRIBED IN ANY FORM WITHOUT THE WRITTEN CONSENT OF CUSTOM CABLE INDUSTRIES, INC. ACCEPTANCE OF THIS DRAWING ESTABLISHES AN AGREEMENT OF THE FOREGOING.		Approved						

FIBER CONFIGURATION					
MPO-24F			LC UNIBOOT		
ROW	COLOR	FIBER		TUBE	POS
1	BLU	1		N/C	B
2	BLU	13		N/C	A
1	ORG	2		1	B
2	ORG	14		1	A
1	GRN	3		2	B
2	GRN	15		2	A
1	BRN	4		3	B
2	BRN	16		3	A
1	SLT	5		4	B
2	SLT	17		4	A
1	WHT	6		5	B
2	WHT	18		5	A
1	RED	7		6	B
2	RED	19		6	A
1	BLK	8		7	B
2	BLK	20		7	A
1	YEL	9		8	B
2	YEL	21		8	A
1	VID	10		9	B
2	VID	22		9	A
1	RDS	11		10	B
2	RDS	23		10	A
1	AQU	12		N/C	B
2	AQU	24		N/C	A

THIS DRAWING MAY CONTAIN PATENTED OR PROPRIETARY INFORMATION AND MUST NOT BE USED FOR ANY PURPOSE DETRIMENTAL TO CUSTOM CABLE INDUSTRIES, INC. IT MAY NOT BE REPRODUCED OR TRANSCRIBED IN ANY FORM WITHOUT THE WRITTEN CONSENT OF CUSTOM CABLE INDUSTRIES, INC. ACCEPTANCE OF THIS DRAWING ESTABLISHES AN AGREEMENT OF THE FOREGOING.

Drawn	B. Baylor	03	06	15
Checked		03	06	15
Approved				

Part No.	C1418-XXX-UM-995		
DRAWING IS NOT TO SCALE	Rev. A	Sheet	2 of 3

P1=OUTSIDE END (OSE)

P2
PREP JACKET BUTT TO 26 INCHES

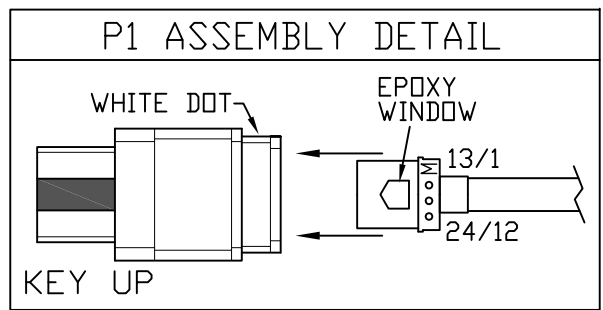
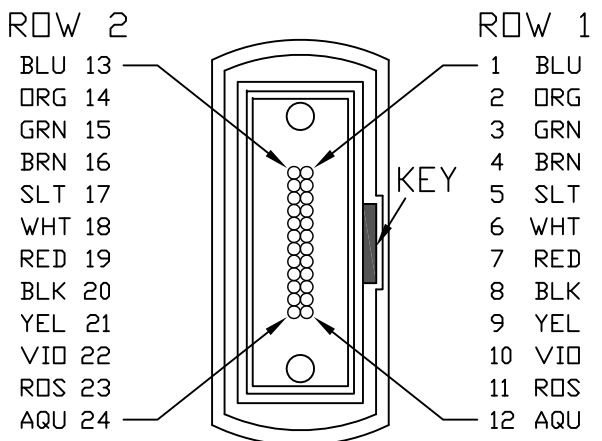
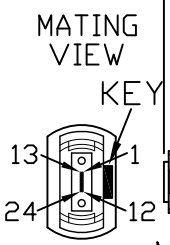
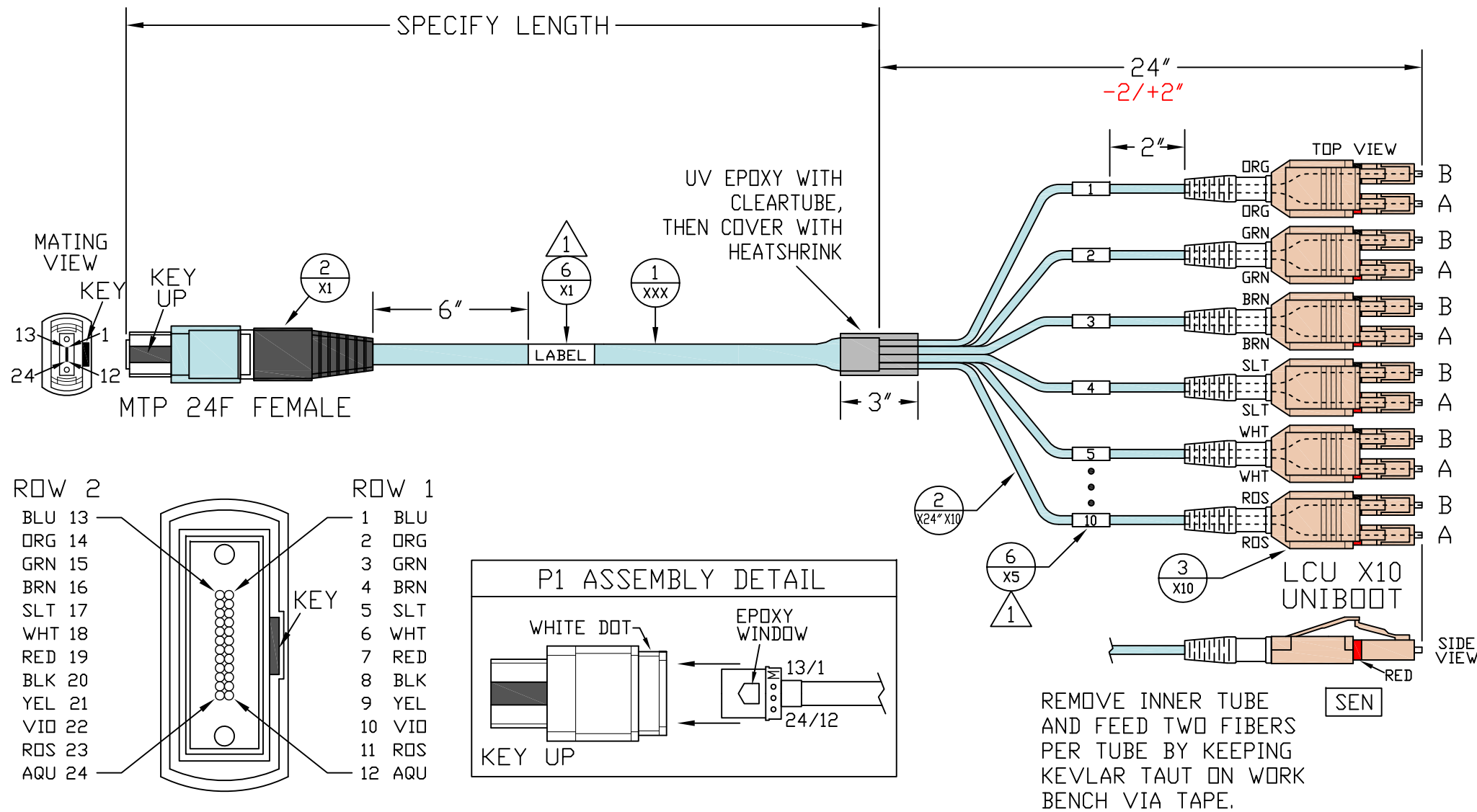

REMOVE INNER TUBE AND FEED TWO FIBERS PER TUBE BY KEEPING KEVLAR TAUT ON WORK BENCH VIA TAPE.

THIS DRAWING MAY CONTAIN PATENTED OR PROPRIETARY INFORMATION AND MUST NOT BE USED FOR ANY PURPOSE DETRIMENTAL TO CUSTOM CABLE INDUSTRIES, INC. IT MAY NOT BE REPRODUCED OR TRANSCRIBED IN ANY FORM WITHOUT THE WRITTEN CONSENT OF CUSTOM CABLE INDUSTRIES, INC. ACCEPTANCE OF THIS DRAWING ESTABLISHES AN AGREEMENT OF THE FOREGOING.	Drawn	B. Baylor	03	06	15	Part No. C1418-XXX-UM-995
	Checked		03	06	15	
	Approved					
						Rev. A Sheet 3 of 3